Memoranda/Mémoires

α_1 -Antitrypsin deficiency: Memorandum from a WHO meeting*

*α_1 -Antitrypsin (AAT) deficiency, also known as α_1 -antiprotease inhibitor deficiency, is a disease caused by genetically determined AAT deficiency. It occurs as a result of inheritance of two protease inhibitor (PI) deficiency alleles from the AAT gene locus (designated PI) on chromosomal segment 14q32.1. The most common deficiency allele is PI*Z and a large majority of individuals with severe AAT deficiency are PI type ZZ. The disease occurs predominantly in white persons of European origin and its frequency in Europe and North America is comparable to that of cystic fibrosis (1 in 2000 to 1 in 7000.) Persons with AAT deficiency may have no clinical manifestations. Chronic obstructive pulmonary disease (COPD) with a high frequency of panacinar emphysema is the most prevalent clinical disorder associated with AAT deficiency and the most frequent cause of disability and death. Tobacco smoking is the major risk factor for developing COPD, which generally begins by the third decade of life, much earlier than "usual" COPD that occurs in AAT-replete individuals. Liver disease, the second most frequent clinical manifestation of AAT deficiency, typically presents as cholestasis in infancy but is usually not severe and generally remits by adolescence. Chronic liver disease develops infrequently, although AAT deficiency is the commonest cause of chronic liver disease in childhood. Cirrhosis and carcinoma of the liver affect at least 25% of AAT-deficient adults over the age of 50 years. AAT deficiency appears to be widely underdiagnosed and based on predicted gene frequencies even in the most intensely studied populations, only a small proportion of those predicted to have AAT deficiency have been diagnosed. Human AAT is available in limited quantity for augmentation therapy.*

This Memorandum summarizes the discussions and recommendations made by participants at a WHO meeting held in Geneva on 18–20 March 1996 to review existing knowledge about this highly prevalent genetic disorder, develop a strategy for enhancing awareness of it among health-care-givers and the general public, and explore new case-finding and disease-prevention strategies.

Biology of α_1 -antitrypsin deficiency: a conformational disease

α_1 -Antitrypsin (AAT), also known as α_1 -protease inhibitor, is the protease inhibitor present in highest concentration in human plasma (1, 2). Its prime physiological target is neutrophil elastase. The serpin family of serine protease inhibitors, to which AAT belongs, share a relatively complex template

structure (3–6), which has the unusual property of being able to change from one conformational form to another (7, 8). This molecular mobility allows these inhibitors to snare a target protease and to enfold it, forming a tight complex that may circulate in the blood for an extended time before it is catabolically cleared. Mutations affecting the domains controlling molecular mobility can allow these conformational changes to take place prematurely with consequent dysfunction and disease (9).

* The participants at the meeting were as follows: Dr A. Barker, Portland, OH, USA; Dr M. Brantly, Bethesda, MD, USA; Dr E. Campbell, Salt Lake City, UT, USA; Dr R. Carrell, Cambridge, England; Dr D. W. Cox, Toronto, Ontario, Canada; Dr A. Dirksen, Copenhagen, Denmark; Dr J. A. Dodge (Vice-Chairman), Belfast, United Kingdom; Dr M. A. F. El-Hazmi, Riyadh, Saudi Arabia; Dr S. Eriksson, Malmö, Sweden; Dr E. K. Ginter, Moscow, Russian Federation; Dr N. G. McElvaney, Bethesda, MD, USA; Dr A. Mehta, Cleveland, OH, USA; Dr A. Propst, Innsbruck, Austria; Dr R. Reprint No. 5795

Sandhaus, Denver, CO, USA; Dr G. L. Snider (Rapporteur), Boston, MA, USA; Dr R. A. Stockley, Birmingham, England; Dr J. K. Stoller (Chairman), Cleveland, OH, USA; Dr I. C. Verma, New Delhi, India; Mr J. Walsh, Coconut Grove, FL, USA; Dr M. Wencker, Essen, Germany; WHO Secretariat: Dr N. P. Napalkov, Dr M. Tsechakovski, Dr V. Boulyjenkov (Secretary), Dr C.-C. Heuck.

Requests for reprints of this article should be addressed to Dr V. Boulyjenkov, Human Genetics Programme, World Health Organization, 1211 Geneva 27, Switzerland.

The most common cause of AAT deficiency is the Z variant of AAT, which is carried by 1 in 25 individuals of Northern European descent (1, 2). This variant results in normal synthesis of antitrypsin but in only 15% secretion, the remaining 85% is blocked in the terminal secretory pathway of the hepatocyte (10). Much of this blocked antitrypsin is degraded but some accumulates as large intracellular inclusions. PI*Z AAT has a mutation (E342K) at the hinge of the reactive loop that affects the entry of the loop into the A-sheet (11, 12). The end result is the loss of the constraints that hold the reactive loop in its external position and the more ready transition of the molecule to the partially incorporated locking form (9). Two variants, Mmalton (FΔ52) (13, 14) and Suyama (S53F) (15), both have abnormalities in the shutter region that controls the sliding movement of the A-sheet to allow entry of the peptide loop containing the reactive centre into the sheet.

The consequences of this more ready conformational transition are twofold: there is a partial block in folding of the protein (16) at the time of synthesis; and a tendency of the fully folded protein to spontaneously flip to the locking form (9). These intermediate forms are susceptible to intracellular catabolism (17) and also to linkage, which results in loop-sheet polymers (18). The tangles of these polymers, visible on electron microscopy, are believed to form the characteristic liver inclusions seen in AAT deficiency. Some of the abnormal AAT is released into the plasma as monomers, but the subsequent formations of polymers in plasma, which are particularly marked in the Suyama variant of the disease (19), contribute to the plasma inhibitory deficiency.

Genetics and molecular biology of α_1 -antitrypsin

α_1 -Antitrypsin locus

The AAT gene locus, designated PI, is located on chromosomal segment 14q32.1, and resides among a gene cluster that includes cortisol-binding globulin, α_1 -antichymotrypsin, 19- α_1 -antitrypsin, α_1 -antitrypsin pseudogene/protease inhibitor-like gene (PI*L) and protein C inhibitor. The entire complex is located within a 280 kb region near the immunoglobulin locus (14q32.33).

The arrangement of these five genes within the cluster is as follows: α_1 -antichymotrypsin/protein C inhibitor, α_1 -antitrypsin, PI*L, and cortisol-binding globulin. The α_1 -antitrypsin and α_1 -antichymotrypsin/protein C inhibitor loci within the 220 kb segment are arranged in opposite

orientations to one another (α_1 -antichymotrypsin and α_1 -antitrypsin). With the exception of the PI*L pseudogene, these genes code for related proteins from the superfamily of serpins, which have substantial amino acid and structural homologies. Cortisol-binding globulin, α_1 -antichymotrypsin, α_1 -antitrypsin and PI*L have a similar exon and intron motif.

α_1 -Antitrypsin genomic organization

The AAT gene consists of seven exons (Ia, Ib, Ic and II-V) and six introns spanning more than 12 kb (Fig. 1). Exon Ia and Ib contain elements responsible for macrophage-specific transcription and exon Ic contains the promoter necessary for hepatocyte-directed transcription. The coding region includes 1434 bp primarily dispersed on four exons. The start codon ATG sequence for the 24 amino acid signal peptide and two of the three N-linked glycosylation sites, N46 and N83, are located in exon II. Exon III contains the last of the three glycosylation sites, N247, and the most common polymorphic site within the coding region V213A. Exon V is the site of the most common mutation associated with AAT deficiency E342K, the active site M358, stop codon TAA and the polyadenylation site (ATAA). With the exception of a small portion of the exon Ia, the entire gene is contained within two EcoRI fragments of 4.8 kb and 9.6 kb.

Between the hepatocyte promoter and the start codon there is a 5.3 kb intron, which contains a 143 amino acid open reading frame, an Alu family sequence repeat, and a pseudotranscription start site. The intron-exon boundaries have conserved consensus sequences with the exception of the 3'-junction of exon Ic.

α_1 -Antitrypsin gene expression

Hepatocyte mRNA is 1.6 kb in length and contains exon Ic, exon II-V and 3'-untranslated sequence. Three macrophage-derived AAT mRNAs (two 1.8 kb and a 2.0 kb) have been identified, and are the product of alternative splicing of exons Ia, Ib and Ic. While the principal site of synthesis is the liver parenchymal cell, AAT synthesis also occurs in mononuclear phagocytes, neutrophils, intestinal epithelium, kidney parenchyma, and several other sites.

Most of the hepatocyte transcription is directed by a 557 bp fragment that begins 20 nucleotides upstream from the transcription start site and contains the TATA box and three elements critical to efficient and tissue-specific transcription. These have been designated the X, Y and P elements and share common features with other promoters of acute reactive hepatocyte-derived proteins. Of these ele-

Fig 1 Organization of the α_1 -antitrypsin gene. Top (5') to bottom (3'), the boxes denote coding elements (exons) of the α_1 -antitrypsin (AAT) gene, the lines between the boxes are intervening sequences (introns). Together, these elements span 12 kb. Exons Ia, Ib and Ic are regulatory elements essential for normal AAT expression. Ia and Ib are macrophage-specific regulatory elements and Ic has both macrophage- and hepatocyte-specific regulatory elements. Exon II encodes the amino acid backbone of AAT. Exon II encodes the start codon (ATG), signal peptide, and two of the three carbohydrate attachment sites (N46-CHO and N83-CHO). Exon III encodes the third carbohydrate attachment site (N247-CHO). Exon V encodes the active site (M358), the stop codon (TAA) and the polyadenylation signal (ATTAA).

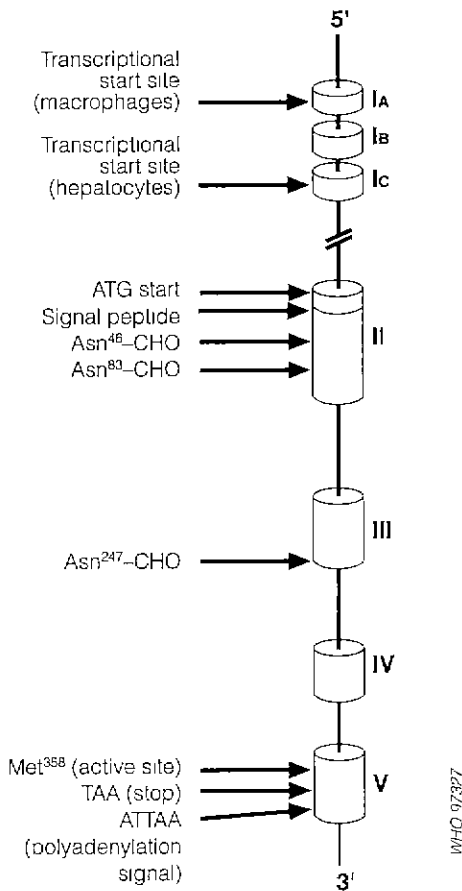

ments, X and P are essential to normal transcription in hepatocytes.

Several transcription factors are involved in the modulation of transcription, including LFB-1/HNF-1, C/EBP, HNF-3 and HNF-1/LFA-1. Together,

both the *cis*- and *trans*-isomers of the hepatocyte promoter play a crucial role in regulating gene expression in a cascade of events that probably includes both cross-regulation and auto-regulation.

IL-6, which is the major cytokine responsible for the acute phase response, up-regulates hepatocyte AAT transcription. IL-1 and TNF, which are also involved in the acute-phase response, do not increase AAT transcription. Up-regulation of AAT transcription mediated by IL-6 probably occurs primarily via transcription factor NF- κ B, which has at least two consensus sequences within the α -antitrypsin promoter.

Normal protein trafficking of α_1 -antitrypsin

Translation of AAT mRNA results in a 418 amino acid protein including a 24 amino acid signal peptide. Within the membrane of the rough endoplasmic reticulum the signal peptide is cleaved from the nascent polypeptide, and glycosylation begins at the moment the peptide reaches the luminal side of the rough endoplasmic reticulum. At the same time as dolichol-linked oligosaccharides are added, protein folding proceeds in the presence of chaperons. After transport to the *cis*-Golgi, the carbohydrate side-chains are trimmed and complex residues are added. Following processing in the Golgi, the $M_r = 52000$ globular glycoprotein is rapidly secreted into the serum. This entire process from translation to secretion takes less than 90min.

Genetic variation at the α_1 -antitrypsin locus

There are at least 49 AAT gene allelic variations characterized by DNA sequencing (as opposed to isoelectric focusing). Approximately 11% of the nucleotide sequence codes for AAT protein sequence and not surprisingly, most of the characterized mutations are found within the protein coding exons, since screening for mutations is most often initiated based on protein variation. The mutations within the protein coding regions are relatively evenly dispersed. Two exceptions to this observation are the codon 51–53 region and the codon 361–362 region. The most likely explanation for the concentration of variants in these locations is that these regions represent mutational "hot spots". Analysis of the nucleotide sequence in both of these regions reveals reiterated DNA sequences which may be sites of slippage misalignment—a mechanism of mutation associated with the deletion or insertion of one or more bases since DNA polymerase "slips" on the monotonous DNA template.

Memorandum

Molecular mechanisms of α_1 -antitrypsin deficiency

The molecular mechanisms responsible for AAT deficiency include errors in the expression, translation, and intracellular processing of AAT. Two variants, QOiso di prociada and QOriedenburg are associated with the deletion of most of the coding region of AAT. QOwest, QOtrastevere and probably, QObonny blue are associated with abnormalities in mRNA splicing or stability. QOhongkong, QOtrastevere, QOclayton and Z are associated with retention in the rough endoplasmic reticulum and intracellular degradation.

Molecular epidemiology of α_1 -antitrypsin deficiency

Population studies

About 100 genetic variants (protease inhibitor (PI) types) of AAT deficiency are recognizable by isoelectric focusing. The distribution of the genetic types (PI alleles) has been determined for many populations (20–22), with PI^*M and its several subtypes, being the most common allele (Table 1).

Deficiency due to the PI^*Z allele

The most common deficiency allele is PI^*Z , and 95% of individuals with AAT deficiency are of PI type ZZ. The highest frequency of PI^*Z is in Scandinavia,

it occurs throughout white populations including those of the Middle East, but is absent from oriental and black populations, except where there is white admixture, as in the USA. The estimated frequency of the PI^*Z allele in North American white populations is 0.0122, corresponding to a frequency of PI^*ZZ homozygotes of 1 in 6700. The frequency of PI^*Z is higher in Scandinavia: 0.026, as calculated from 200000 Swedish neonates in a newborn screening programme (23).

Rare deficiency alleles

The 5% of AAT-deficient persons who are not PI^*ZZ are accounted for by about 20 rare variants. These variants are important: they are not identified by PI typing; prognosis may differ from that for PI^*ZZ ; and they provide insight into residues important for normal protein function. Deficiency alleles may produce amounts of plasma AAT similar to that of the PI^*Z allele or may produce no detectable AAT by standard methods.

Alleles associated with detectable α_1 -antitrypsin

Table 2 lists those mutations which produce deficiency and dysfunctional alleles with plasma concentrations of generally about 2–15% of normal. These variants have an isoelectric point by PI typing different from that of the Z variant (24). Family studies, and ultimately DNA analysis, confirm the presence of these rare deficiency alleles.

Table 1: Protease inhibitor (PI) allele frequencies for α_1 -antitrypsin deficiency in selected populations^a

Population	No tested	PI alleles					
		M1	M2	M3	S	Z	Other
Denmark	909	0.728	0.136	0.082	0.022	0.023	0.009
Netherlands	357	0.679	0.147	0.129 ^b	0.029	0.013	0.003
Portugal	900	0.510	0.260	0.053	0.150	0.009	0.018
U S (White)	904	0.724	0.137	0.095	0.023	0.014	0.007
U S (Black)	549	0.982	—	—	0.015	0.004	—
China ^c	1010	0.709	0.209	0.070	—	—	0.012
Japan	746	0.786	0.153	0.062	—	—	—
France	1653	0.902 ^d	—	—	0.071	0.014	0.007
Greece	504	0.960 ^d	—	—	0.028	0.002	0.006
United Kingdom	4042	0.930 ^d	—	—	0.052	0.014	0.004
Saudi Arabia	204	0.926 ^d	—	—	0.052	0.022	—
India	430	0.994 ^d	—	—	—	0.006	—

^a See ref 20–22

^b Frequency of PI^*M3 plus PI^*M4

^c Mean of five Chinese populations

^d M (all M subtypes)

Table 2: Deficient and dysfunctional α_1 -antitrypsin alleles

Allele	Base ^a	Exon ^b	Mutation
<i>Deficient</i>			
F	M1(Val213)	III	R223C (CGT → IGT)
Z	M1(Ala213)	V	E342K (GAG → AAG)
T	M2	III	E264V (GAA → GTA)
S	M1(Val213)	III	E264V (GAA → GTA)
Mheerlen	M1(Ala213)	V	P369L (CCC → CVC)
Mmalton	M2	II	F52 (TTC → Delete)
Mmineralsprings	M1(Ala213)	II	G67E (GGG → GAG)
Mprocida	M1(Val213)	II	L41P (CTG → CCG)
Wbelhasda	M1(Val213)	V	A336T (GCT → ACT)
I	M1(Val213)	I	R39C (CGC → TGC)
Mpaiermo	M1(Val213)		F51 (TTC → Delete)
Mnichinan	M1(Val213)	I	F52 (TTC → Delete)/G148R (GGG → AAG)
Plowell	M1(Val213)	III	D266V (GAT → GTT)
Pduarte	M4	III	D266V (GAT → GTT)
Siiyama	M1(Val213)	II	F53S (TTC → TCC)
Zaugsburg	M2	V	E342K (GAG → AAG)
<i>Dysfunctional</i>			
Pittsburg	— ^c	V	M358R

^a Indicates the base allele

^b Indicates the exon where the mutation is located.

^c Unknown.

The null (QO) alleles

The null alleles (PI^0QO , homozygotes designated as PI^0QOQO) are associated with no AAT, or <1% of the normal amount of plasma AAT. The null alleles are widespread. Among 112 patients with AAT deficiency, Brantly estimated the frequency of all null alleles to be 1.7×10^{-4} , about 1/100th that of the PI^0Z allele in a North American white population and similar to that of $PI^0Mmalton$ (25).

DNA polymorphisms

In addition to the extensive variation found in the protein by electrophoretic methods, variation is found in the DNA sequence, as recognized by restriction enzymes, producing restriction fragment-length polymorphisms (RFLPs). At least seven RFLPs have been identified within or adjacent to the gene, or in the adjacent downstream homologous sequence (26, 27).

DNA polymorphisms and haplotypes are of particular interest for evolutionary studies. A specific DNA haplotype is associated with the PI^0Z allele and indicates a single origin for all PI^0Z alleles (28). The DNA haplotype is the same irrespective of ethnic group within northern Europe, and independent of the presence or type of clinical disease. Specific DNA haplotypes are associated with each of the protein variants and can be used to identify the evolutionary pathways (26). They have also been useful as a first step for the identification of specific rare deficiency alleles (24).

Clinical manifestations of α_1 -antitrypsin deficiency

Chronic obstructive pulmonary disease

Chronic obstructive pulmonary disease (COPD), i.e. the occurrence of airflow obstruction due to the presence of chronic bronchitis or emphysema, is the most prevalent clinical disorder associated with AAT deficiency. About 95% of patients with severe AAT deficiency are PI^0Z homozygotes. Their serum levels are about 15% of normal (5–6 $\mu\text{mol/l}$ (30–40 mg/dl) compared with normal serum values of 20–53 $\mu\text{mol/l}$ (150–350 mg/dl)). Other phenotypes that may be associated with disease include PI^0 Null variants and some PI^0SZ individuals (29).

Emphysema is the dominant lesion in AAT deficiency, with basilar predominance a distinctive although not diagnostic feature. In the largest available series, of 165 PI^0Z homozygotes examined with plain chest radiographs, 85% ($n = 140$) had some radiographic features of emphysema; and of these individuals 99.8% had emphysematous changes that included the lung bases, while 24% had emphysematous changes confined to the lung bases (30, 31).

The severity of airflow obstruction in AAT deficiency, age at presentation of respiratory symptoms, physiologically demonstrable airflow obstruction, and mortality vary widely and are strongly related to habitual tobacco smoking. Lung disease rarely occurs in childhood (32). Individuals who have never

Memorandum

smoked rarely develop respiratory symptoms before the fifth decade and impairment of forced expiratory spirometry, which is usually mild, is not detectable before the sixth or seventh decade; occasionally, however, severe airflow obstruction develops among those who have never smoked (33). In the U.S. Registry for Patients with Severe Deficiency of Alpha-1-Antitrypsin (35), the mean age \pm SD of the 1129 participants was 46 ± 11 years and their mean FEV₁ \pm SD was $43 \pm 30\%$ predicted. In Larsson's series of 246 PI*Z adults with a median age of 52 years, COPD was present in 74.8% of the participants (36).

Chronic bronchitis. In contrast to emphysema, which is defined on the basis of its pathology, chronic bronchitis is defined on a clinical basis as chronic productive cough with no evident etiology, occurring for more than 3 months per year in each of two successive years. In Eriksson's series of 35 patients, 20% had chronic bronchitis (37) and in Brantly's series of 120 patients, 34% had chronic bronchitis (29). In the British Thoracic Association survey, 59% of 132 smokers had chronic bronchitis, compared with only 29% of those who had never smoked (33).

Environmental air pollution. There is little information on the effects of polluted air on the occurrence of COPD among those with AAT deficiency. However, the effects of air pollution on conventional COPD have been extensively studied.

The pollutants for which there is most information are ozone, sulfur dioxide, oxides of nitrogen, acid aerosols, and particles. Changes in morbidity (emergency admissions to hospital) and mortality have been related to changes in ambient sulfur dioxide levels (38). Most research on particulates has focused on respirable particles (<10 μ m diameter, designated PM10). Statistically significant but small positive associations have been described between PM10 levels and increased severity of airway obstructive disease and asthma (39) and admissions for COPD (40). Having a job with a high degree of exposure to airborne siliceous dusts, metal gases, agents associated with aluminum production, and welding increased the sex-, age-, and smoking-adjusted odds ratios for obstructive lung disease (asthma and COPD) by 3.6 compared with having a job without such airborne exposure (41). The effects of smoking on symptoms and lung function impairment in AAT replete and deficient persons are many times more powerful than the effects of either urban or occupational air pollution.

Infection. Lower respiratory infections in early childhood may be associated with COPD in adult life (42, 43). Lower respiratory infection has also been

identified as a risk factor for chronic airflow obstruction in adults with severe AAT deficiency (36, 44). The predominant organisms causing infection in persons with COPD are *Haemophilus influenzae*, *Streptococcus pneumoniae* and *Moraxella catarrhalis* (45).

Unidentified genetic factors. In AAT deficiency, the presence of emphysema in a parent or the presence of asthma appear to increase the risk of developing COPD. In a recent series of 52 persons of PI*Z type, 22 individuals who were ascertained because they had COPD (index cases) had a lower FEV₁ (28.7% predicted) than 30 persons who were nonindex cases (mean FEV₁ 76.4% of predicted) (44, 46). Only 10 of the 30 nonindex cases had FEV₁ values \leq 65% predicted. These data suggest that unidentified genetic factors may influence disease severity in AAT deficiency.

Lung pathology in AAT deficiency. Understanding about the lung pathology of AAT deficiency is based on descriptions from inflation-fixed specimens from only 14 autopsies. Panacinar emphysema (PAE) in which all elements of the acinus are uniformly involved by airspace enlargement and destruction was present in all the lungs. Emphysema, which results in loss of elastic recoil and of airspace attachments to small poorly supported airways, is an established cause of irreversible airflow obstruction in COPD. Bronchiolar pathology (cellular infiltration, goblet cell metaplasia, fibrosis, luminal secretion and increased smooth muscle) is a cause of both irreversible and reversible airflow obstruction in COPD (47). Neither bronchial nor bronchiolar pathology has been well described in AAT deficiency, although the high frequency of bronchial hyper-reactivity makes bronchiolar disease and some airflow obstruction on that basis almost certain. Pathological studies of specimens from lung transplantation for AAT deficiency provide an opportunity to correct this important hiatus in our knowledge.

Pathogenesis of emphysema in AAT deficiency. Experimental studies have shown that elastases, particularly human neutrophil elastase (HNE), which overcome the antielastase defences of the lungs and reach the elastic fibres in the alveolar wall, cause elastin degradation and give rise to emphysema: non-clastolytic enzymes do not have this effect. AAT has the property of permanently inactivating HNE. It has been hypothesized that in AAT deficiency, emphysema results from an imbalance between the elastases and the sharply decreased amount of AAT present in the lungs. The induction of emphysema by smoking can be explained by the four- to fivefold increase in total lavageable lung

cells (both neutrophils and macrophages) induced by smoking. Thus, the elastase burden of the lungs is increased and the elastase-antielastase imbalance is increased. Oxidants from cigarette smoke and from intrinsic systems in the neutrophil and macrophage can make AAT incapable of inactivating HNE by oxidizing Met³⁵⁸ (the centre of the active site of the molecule), thus further contributing to the elastase-antielastase imbalance. Macrophages in contact with elastic fibres can also degrade elastin by a constitutively produced metalloclastase. The metalloclastase is inactivated by tissue inhibitor of metalloprotease, which is also produced by macrophages (48).

Desmosine and isodesmosine are cross-linked lysine-containing amino acids that are derived only from elastin and which are not metabolized. Thus, their excretion in the urine is an indicator of excess elastin degradation in the body, although clinical evidence is needed to infer the origin of the damaged elastin in the lungs. Stone (unpublished data) has produced evidence that urinary desmosine is increased in AAT deficiency to about the same level as in common COPD, thus providing more direct evidence for elastin destruction as the cause of emphysema (Fig 2).

Fig 2. Mean \pm SE of urinary desmosine (DES) in three groups: 22 normal individuals who have never smoked (PI*M); 28 A-1-ATD persons, a mix of smokers, ex-smokers and those who have never smoked (PI*Z), and 21 current and ex-smokers with COPD.

a These two patient groups were significantly different from the normal group ($P < 0.01$).

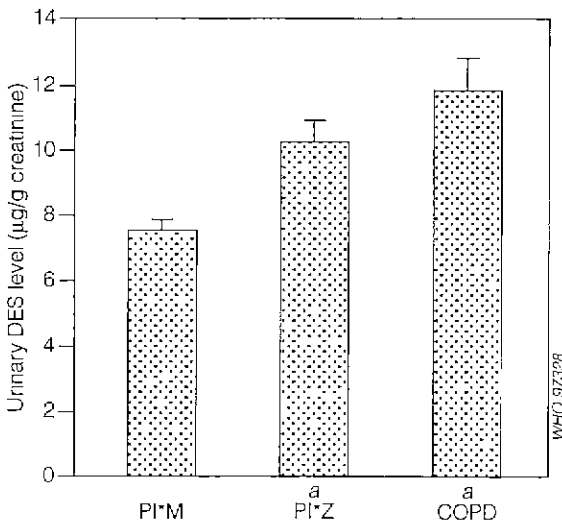

Pathogenesis of chronic bronchitis in AAT deficiency.

Although tobacco smoking is the most important risk factor for chronic bronchitis, elastase-antielastase imbalance may be its more proximate cause. HNE induces permanent secretory cell metaplasia in the bronchi of hamsters. Secretory leukocyte inhibitor, which is produced by the bronchial glands, accounts for 80% of the elastase inhibitory capacity of sputum in chronic bronchitis (49) and HNE is among the most potent of mucus secretagogues.

Asthma and AAT deficiency. As in patients with usual COPD, bronchial hyper-responsiveness is common among AAT-deficient individuals, affecting 20–27% of them (50). The frequency of reported asthma in such individuals has been reported to range from 4% to 34% (33, 34, 36, 37). For a series of 52 subjects, it was reported that chest wheeziness apart from colds, attacks of wheezing and self-reported asthma were all significantly more frequent ($P < 0.02$) in the 32 persons with $FEV_1 \leq 65\%$ predicted than in the 20 persons with $FEV_1 > 65\%$ predicted, suggesting that atopic disease might be a risk factor for development of airflow obstruction in AAT deficiency (44).

Bronchiectasis and AAT deficiency. Although fewer than 100 cases of bronchiectasis associated with AAT deficiency have been reported (50) and the only available case-control study of bronchiectasis failed to demonstrate an association with AAT deficiency, there is little doubt of an association between the condition and AAT deficiency. Brantly (personal communication) reports a 5–10% prevalence of bronchiectasis in 143 patients by tomography; the bronchiectasis involved is most often cylindrical, the type known to occur as part of the lung pathology in usual COPD.

Prognosis and natural history of pulmonary disease.

Understanding about the natural history of AAT deficiency is incomplete. Lung function is generally well preserved in the first two decades of life. Available estimates of yearly decline in FEV_1 among adult smokers range from as low as 42 ml per year to as high as 317 ml per year (57, 74–78) (Table 3).

In an 11-year follow-up study of 246 PI*ZZ homozygotes, Larsson reported a 37% mortality rate, most frequently ascribed to respiratory failure (59% of deaths), but with a minority of deaths (13%) due to complications of liver disease (36). In a study evaluating survival among 120 PI*Z homozygotes referred to the National Institutes of Health, Brantly et al. reported that the actuarial survival to age 60 years among PI*Z subjects was 16% compared with

Memorandum

Table 3 Estimates of the rate of decline of FEV₁ among α_1 -antitrypsin deficient individuals

Study, year (ref)	Source	No. potentially eligible PI*ZZ	No. recruited	Mean FEV ₁ slope (ml/yr decline)		
				Current smoker	Ex-smoker	Never smoked
Janus et al., 1985 (34)	Laboratory roster	84	35 (42) ^a	317	61	80
Hutchison et al., 1987 (79)	Registry	164	82 (50)	67	44	66
Wu & Eriksson, 1988 (80)	Reference laboratory	346	80 (23)	61	81	61
Brantly et al., 1988 (30)	NIH referral	120	24 (210)	51	—	—
Buist et al., 1983 (81)	Pooled data	298	105 (35)	104-111 ^b (30% < FEV ₁ % predicted < 65%) 42-46 (65% < FEV ₁ % predicted)		
Seersholm & Kok-Jensen, 1995 (51)	Danish registry	612	161 (26)	132	58	86

^a Figures in parentheses are percentages

^b Pooled data

an expected age-matched U.S. survival of 85% (30). While referral bias may cause mortality rates in these studies to be overestimated, it seems clear that severe AAT deficiency significantly shortens survival.

In the Danish AAT deficiency registry of 591 subjects with PI type ZZ or ZO, of whom 192 were identified by family studies, the overall median life expectancy was 54 years: 52 years for smokers and 67 years for those who had never smoked; 49 years for the index group; and 69 years for the nonindex group. The life expectancy of persons in the nonindex group who had never smoked was not different from that of the normal Danish population (52).

Under-recognition of AAT deficiency. There is strong evidence from estimates of the frequency of AAT deficiency in populations of persons with COPD (53) and from the frequency of the gene defect based on direct population studies (1/1575 to 1/5097) (23, 44) that the proportion of AAT-deficient persons who have been identified is a small fraction of those actually in the population: 4.5% in the United Kingdom (33), 6% in Sweden (36), and about 5% in the USA (see *Rationale for screening*, below). One reason for under-recognition may be failure of physicians to associate manifest COPD with AAT deficiency. A poll of 304 individuals diagnosed to have severe AAT deficiency found an average delay of 7.2 years between the first onset of symptoms and the initial diagnosis of the condition; 43% of respondents reported seeing at least three physicians and 12% reported seeing 6-10 physicians before the correct diagnosis was made (54). It is not known what proportion of severely AAT-deficient persons, particularly nonsmokers, have no clinical manifestations.

Liver disease

Childhood onset. Screening of 200 000 Swedish neonates identified 120 PI*ZZ children (23) and provides the best estimate for risk of liver disease. During the neonatal period, about 70% develop abnormal liver function tests but only about 10% have clinically significant symptoms. Suggested risk factors for the development of progressive disease among the children who develop hyperbilirubinaemia during the early weeks of life include being male and having viral hepatitis B, while breast feeding reduces the risk. At 8 years of age, liver cirrhosis with early death occurred in only three children (2.4%), i.e. in 13.6% of those PI*ZZ children with clinical evidence of liver abnormalities in infancy (Fig. 3). However, AAT deficiency and biliary atresia are the two leading indications for liver transplantation in children (55).

Adult onset. Cirrhosis and fibrosis of the liver were noted in Swedish adults with AAT deficiency (56). Among PI*ZZ patients ascertained through hospital admissions, 12% had liver cirrhosis (36). In a series of 115 adults with AAT deficiency, four had biopsy- or autopsy-proven cirrhosis and two had definite biochemical evidence of liver disease, providing a total of 5.2% affected with liver disease (57). The risks for developing liver disease were higher for males than females and reached a peak of 15.4% at age 51-60 years.

Pathology of liver disease in AAT deficiency. In contrast to lung disease, the serum concentration of AAT can be 40% greater than normal in infants or children with liver disease. Liver biopsy in jaundiced

Fig. 3. Distribution of liver test abnormalities in AAT-deficient children aged 1–18 years. Reproduced with permission from: Sveger T, Eriksson S. The liver adolescents with α_1 -antitrypsin deficiency *Hepatology*, 1995, 22: 514–517.

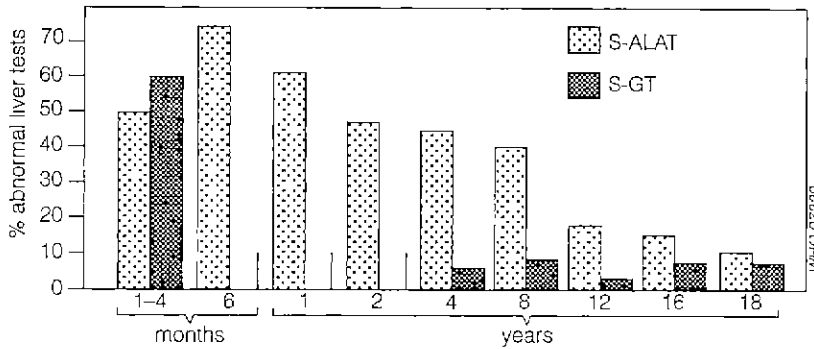

infants typically shows cholestasis, giant cells, and minimal portal inflammation; there may also be fatty infiltration and cellular infiltration around the portal tracts. The development of cirrhosis is presaged by bile duct proliferation and portal tract fibrosis (58).

In adults with AAT deficiency, diastase-resistant, periodic-acid-Schiff-positive (PAS-D) globules, proven by specific immunostaining to be AAT, are present within perportal hepatocytes. Liver biopsies of individuals with disease are characterized by lymphocytes in close proximity to areas of abundant PAS-D globules. As the disease progresses, the liver becomes fibrotic and occasionally displays piecemeal necrosis; bile duct proliferation, liver cell dysplasia and hepatocellular carcinoma may occur. The absence of both hepatocyte inclusions and of liver disease in the null variants of AAT deficiency, in which the liver cells do not produce the protein, provides powerful evidence of a causal association between PAS-D inclusions and liver disease.

Natural history of liver disease. The natural history of liver disease in adults is incompletely understood. Environmental factors clearly play a role in the pathogenesis of liver injury in AAT-deficient individuals. Up-regulation of AAT synthesis during an inflammatory response tends to increase steady-state levels of abnormality folded AAT molecules in the hepatocytes and can thereby initiate hepatotoxic consequences. Factors that accumulate during the inflammatory response, such as bacterial endotoxin, interleukin 6, interleukin 1, NF- κ B and elastase-AAT complexes, are capable of up-regulating AAT synthesis by a distinct mechanism. These findings suggest that an infectious agent or episode may induce

liver injury, since increased levels of AAT were found in PIZZ patients with chronic liver disease. Much information has come from serial case-control studies in Malmö where the autopsy frequency has been high (59), and the gene frequency in the population is well established. There is an increased risk for cirrhosis and hepatocellular carcinoma, particularly among males. This risk seems to be unrelated to alcohol abuse or viral hepatitis. The absence of hepatitis B or hepatitis C viruses among cases, despite careful testing of stored sera in Malmö, is important in view of more recent studies from Innsbruck, Austria, which report that the risk of developing chronic liver disease is unrelated to alcohol abuse, but may be increased by viral hepatitis B or C infection, particularly in heterozygous patients (58, 60). Furthermore, a higher susceptibility to viral infection was found in patients with AAT deficiency than in those with no such deficiency. Being male was confirmed to be an independent risk factor for the development of chronic liver disease. The absence of viral coinfection in the Swedish autopsy study on stored sera is controversial and may be explained by a low incidence of viral hepatitis B or C in North European countries, but this requires further study.

Dermatological manifestations

Panniculitis, characterized by inflammatory and necrotizing lesions of the skin, represents the least common of the well-recognized complications of AAT deficiency, with only 26 cases having been reported in the English literature up to 1991 and fewer subsequently (61). The prevalence among AAT-deficient individuals is probably less than 1 case per 1000. Panniculitis has accompanied a variety of phe-

Memorandum

notypes, including PI*ZZ, PI*MZ, PI*SS, and PI*MS. The inflammatory skin lesion is thought to result from unopposed proteolysis in the skin, which has been triggered by an unidentified immune phenomenon.

Psychosocial impact of AAT deficiency

Impact of neonatal screening

In the nationwide neonatal screening programme for AAT deficiency in Sweden, identification of the condition in neonates had negative psychological effects in some families. The following recommendations resulted from a systematic study of the psychological and psychosocial consequences of screening (62):

- parents should be informed in advance of AAT testing of the phenylketonuria sample;
- AAT deficiency should be identified and parents informed early;
- a doctor's appointment should be specially arranged;
- appointments should ideally be attended by both parents;
- written information should be made available;
- repeated informative appointments should be scheduled; and
- the same physician should see the parents at each visit.

Impact on patients with AAT deficiency

Not surprisingly, AAT deficiency exacts a psychosocial toll on affected persons. In a recent survey of 1730 subscribers to a national AAT newsletter in the USA, 414 questionnaires were returned: 75.3% of respondents with severe deficiency reported at least one adverse effect of their disease: 44.4% retired early, and 19.1% changed to a physically easier job (54). The duration of diagnostic delay, which was frequently several years, correlated with the degree of adverse psychosocial effects.

Alpha-1 National Association

The need to share support and information provided the impetus for a national patient organization in the USA, the Alpha-1 National Association (A-1NA). The founders of the A-1NA were among the original participants in studies of infusion therapy with purified AAT at the National Institutes of Health. The

goal of the association is to improve the lives of those affected by AAT deficiency through support, education, and research. Education and training of board members, patient members, families, and friends has been paramount. Other important activities include dissemination of educational materials, lobbying for research funds, raising funds for ongoing operations, facilitation of national support groups, publishing and distribution of the national newsletter (the Alpha-1 News, with about 2000 subscribers), an information hotline (AlphaLine, 1-800-4ALPHA1), free public screenings for AAT deficiency, and an informational CD-ROM for patients and health professionals (AlphaMedia). The guiding principle of the A-1NA has been that knowledge about AAT deficiency ameliorates its impact.

Augmentation therapy of AAT deficiency

Intravenous AAT augmentation therapy

Because many PI*SZ individuals whose serum AAT levels exceed 80mg/dl (11µmol/l) do not develop emphysema, this level was chosen as a target for augmentation therapy of AAT deficiency. Among the 21 patients who received a once-weekly infusion of 60mg per kg body weight of plasma-derived AAT concentrate the mean lowest AAT level was 126mg/dl compared to a mean pre-therapy level of 30mg/dl. The half-life of infused AAT, estimated at 4.5 days, was maintained over the 2-year study period, suggesting no increase in catabolic breakdown or anti-body formation in response to the AAT infusions. Measurement of serum anti-neutrophil elastase capacity confirmed the functional activity. Monthly bronchoalveolar lavage at 2-6 months showed AAT levels and anti-neutrophil elastase capacities in bronchoalveolar lavage fluid that were above the amount estimated to prevent alveolar destruction. The results of this study formed the basis for the U.S. Food and Drug Administration's approval in 1988 of the pooled plasma concentrate (Prolastin, Bayer), for treatment of severe AAT deficiency in the USA. It seemed reasonable to assume that if enough AAT were given intravenously to maintain serum levels above the target level, emphysema would not develop in a nonsmoker. Approximately 2200 individuals are currently receiving Prolastin in the USA and its use has been approved in Canada, Germany, and Spain, where a total of approximately 2000 patients are receiving it. In France, 16 patients are receiving a different plasma concentrate

Hubbard et al. evaluated an AAT dose of 250 mg/kg given every 28 days to 9 patients for 1 year (63). These patients maintained serum AAT levels of 70–80 mg/dl for 20 days of a 28-day infusion interval: the mean (\pm SE) lowest serum AAT level after the 12th infusion was 67 ± 10 mg/dl. The bronchoalveolar lavage AAT levels and anti-neutrophil elastase capacities at 28 days were above the target threshold, suggesting maintenance of protection at the alveolar level even though protective serum levels were not sustained for the 28-day cycle. Cammarata et al. were unable to reproduce these results with five patients on monthly augmentation therapy (64). For three patients studied weekly over two monthly cycles, lowest levels were between 25 mg/dl and 40 mg/dl. The U.S. Food and Drug Administration has approved Prolastin use only for infusion of 60 mg/kg at 7-day intervals.

Recombinant DNA-directed AAT is a non-glycosylated protein produced by yeast encoding the normal human AAT except for a terminal methionine and three carbohydrate chains. Recombinant AAT has a half-life of a few hours due to rapid renal clearance from the blood and its intravenous use is therefore not feasible (65).

Investigations of whether augmentation therapy actually retards emphysema progression have been hampered by the long intervals needed for study, lack of a suitable, noninvasive, objective marker of emphysema, the large numbers of patients needed, and the expense of such trials. The change in FEV₁ has become the marker for progression or halting of emphysema. It has been estimated that such a trial would need 250 patients in each arm of a placebo versus AAT augmentation trial followed for 3 years.

Two preliminary reports address the issue of efficacy of augmentation therapy. Seersholm compared the annual change in FEV₁ among 235 German patients for 2–6 years on Prolastin and 161 Danish patients for 7 years not on Prolastin. In this retrospective study, the FEV₁ declined by 63 ml per year in the German patients (treated group) and 81 ml per year in the Danish patients (untreated group); the difference was not significant (66). A European multicentre double-blind randomized trial which is in its fifth year, consists of 25 patients in a two-arm study: Prolastin (250 mg/kg every 28 days) versus placebo (albumin). The end-points are changes in pulmonary function and annual CT scan findings. Finally, the U.S. National Heart, Lung, and Blood Institute (NHLBI) Registry of Patients with Severe Deficiency of AAT (enrolment, 1129 patients) includes individuals both receiving and not receiving Prolastin. Although not a clinical trial, analysis of the decline in FEV₁ is currently being finalized, and publication of these results is expected soon.

Safety of intravenous AAT therapy

During the 8 years of clinical experience with Prolastin infusions in the USA, reported side-effects have been relatively few. Headaches, myalgias, arthralgias, and low back pain are the most frequent complaints requiring no treatment or occasional analgesic use. Deterioration of shortness of breath, probably due to increased protein load with the infusion, may occur in patients with severe COPD or heart failure. No confirmed serious viral diseases have occurred as a result of AAT infusion. Nevertheless, it is recommended that studies to determine infection status with hepatitis and human immunodeficiency virus (HIV) be carried out before initiating infusion; individuals with a nonprotective titre against hepatitis B virus should be immunized.

Several lots of Prolastin were recalled in 1994 and 1996 since the plasma used in the purification process had been donated by individuals with suspected Creutzfeldt-Jakob disease (CJD), which has, however, not been documented to be transmitted by blood products. Although acute allergic or anaphylactic reactions have been few, it is important to be aware that patients who have severe AAT deficiency may also rarely be IgA deficient. Prolastin contains some IgA, and acute anaphylaxis has been well documented in IgA-deficient PJZZ patients receiving regular augmentation therapy (Brantly, unpublished observation).

Augmentation of AAT by aerosol delivery

Direct delivery of AAT to the lung by aerosol has been explored because only 2% of intravenously administered AAT reaches the lungs, with the remainder being distributed throughout other body tissues. Since the lung is the major organ to be affected by the excessive elastase burden in AAT deficiency, aerosol administration using plasma concentrates of AAT and rAAT is currently under investigation.

Synthetic elastase inhibitors for treating AAT deficiency

Several commercial enterprises are hoping that the expense, inconvenience, and limited supply of plasma AAT might be overcome by using a synthetic elastase inhibitor to treat AAT deficiency. Synthetic inhibitors of HNE have been based on the identification of its active site specificity. In general, the smallest peptide inhibitors of HNE have started with the basic Val-Pro-Val or Ala-Pro-Val tripeptide structure identified as being most sensitive and selective for HNE in substrate-based enzymatic assays. Rational chemical design has been based on desired kinetics and route of administration and molecular

Memorandum

modelling has been employed for this purpose. Serendipity has played a role in the development of some inhibitors. For example, nonpeptide compounds evolved from an evaluation of the elastase inhibitory properties of cell-wall-bound nucleic acids in bacteria and compounds gaining oral activity and cell penetration by incorporating the lactam moiety of cephalosporin antibiotics.

Lung transplantation for AAT deficiency

Up to September 1995, more than 4300 patients (about 30% with COPD) had undergone lung transplantation worldwide. The 6-year actuarial survival for recipients of all types of lung transplant is approximately 40%; emphysema patients have a 4-year survival rate of 54%, the best level of all groups. Most survivors have experienced useful functional improvement. Because of the shortage of suitable lung donors, most patients now receive a single lung transplant.

Approximately 12% of lung transplants are performed for emphysema caused by AAT deficiency. AAT-deficient recipients are about 6–7 years younger than other COPD patients and have an actuarial survival of 45% at 5 years.

Lung volume reduction surgery

Lung volume reduction surgery (LVRS) consists of multiple wedge resections of the most severely involved emphysematous lung (target areas), identified by imaging. Surgical decrease of marked hyperinflation is believed to improve both the mechanical properties of the respiratory system and blood-gas exchange. Those with widespread, uniform emphysema, pulmonary hypertension (mean pulmonary artery pressure >4.67 kPa (35 mmHg)), severe hypercapnia ($p_a\text{CO}_2 > 7.33$ kPa (55 mmHg)), very low FEV₁ ($<20\%$ of predicted), and skeletal deformities are considered less than ideal candidates. These exclusion criteria are, however, arbitrary and need validation. Reported mortality, usually from respiratory failure, is about 5%. Improvement in FEV₁ is highly variable with improvement in dyspnoea and 6-minute walking distance often greater than changes in FEV₁. Benefits have lasted for 1 year, the maximal length of follow-up to date. Only a few patients with AAT deficiency have undergone LVRS and no data have been reported. Randomized controlled trials to evaluate LVRS are in their early stages.

Prospects for gene therapy in AAT deficiency

AAT deficiency is theoretically an attractive target for gene therapy since the AAT molecule functions extracellularly and has a broad safety margin. The phenotypical abnormality, deficiency of AAT, could be corrected by transferring the normal human AAT cDNA to the cells of deficient individuals — and these cells could be anywhere in the body — as long as sufficient AAT reaches the lower respiratory tract. However, gene therapy represents a radical intervention and it is generally regarded that the condition to be treated in this way must have no effective alternative therapy. This is a moot point for AAT deficiency; augmentation therapy with AAT is available but is expensive, inconvenient, and in short supply.

Three general transfer strategies have been evaluated in AAT deficiency: retroviruses, adenoviruses, and nonviral vectors. For gene therapy, the retrovirus is modified to make it able to enter the cell and insert the new gene into the genome but incapable of directing the cell to produce infectious retrovirus. An early study involving administration of modified fibroblasts intraperitoneally to mice demonstrated that cells not normally producing AAT could be targeted by retroviral vectors to produce the protein (67–70). Unlike retrovirus, adenovirus DNA functions extrachromosomally (71) so that mutagenesis is not an issue, however, the therapy will have to be given periodically since the genetic modification of the target cell is not passed on to its progeny. No adenoviral-based strategies have been able to produce therapeutic levels of AAT (72).

Liposomes are artificial lipid bilayers designed to transfer nucleic acids into the cell cytosol via cell-membrane fusion. A plasmid containing the AAT cDNA and a cytomegalovirus promoter complexed to cationic liposomes has been given intravenously and by aerosol to rabbits (73), showing AAT protein in the pulmonary endothelium.

Molecular conjugates represent another non-viral system consisting of plasmid DNA complexed to polylysine and a molecule that targets the DNA complex to a specific cellular receptor. These vectors are not efficient and require further development (74).

Current status of worldwide registries for AAT deficiency

Three major studies are currently investigating the natural history and efficacy of intravenous augmen-

tation therapy with human AAT in patients with severe AAT deficiency and pulmonary emphysema. The U.S. registry is a multicentre surveillance study coordinated by the National Heart, Lung, and Blood Institute of the National Institutes of Health to assess the natural history of AAT deficiency in individuals receiving and not receiving intravenous AAT augmentation therapy (35). Change in FEV₁ and survival are the end points. Between March 1989 and October 1992, a total of 1129 individuals were enrolled. The Danish-Dutch study — the European Randomized Placebo-controlled Trial of alpha₁-Protease Inhibitor Replacement Therapy (75) — was designed as a double-blind, placebo-controlled study using the decline in FEV₁ as the primary end point: 57 patients were enrolled. The aim of a German multicentre surveillance study (the Westdeutsche Arbeitsgemeinschaft zur Therapie von Lungenerkrankungen (WATL) Multicentre Trial of α_1 -PI Augmentation Therapy in Patients with α_1 -PI Deficiency) was to evaluate the efficacy of intravenous AAT augmentation therapy using FEV₁ and survival as primary end points. This study includes 443 patients with severe AAT deficiency and pulmonary disease, all of whom receive weekly augmentation therapy with 60 mg per kg human AAT; a placebo control group was not considered ethical.

Because of the small number of known patients with AAT deficiency and the slow progression of pulmonary emphysema as well as other constraints, the planning and performance of each study has been accompanied by doubts about the protocol, the required number of patients, and the time needed to reach a statistically significant result. The three groups discussed above chose different strategies to solve these problems and results from these studies will soon be available. None, however, will answer all the important questions, but together, they should expand our knowledge of the natural history of AAT deficiency and provide the basis for developing new national strategies for managing the disease.

Screening for AAT deficiency

Rationale for screening

AAT deficiency is one of the most prevalent, potentially lethal hereditary diseases among Caucasians. Health care providers have often been reluctant to test for "uncommon" hereditary diseases such as AAT deficiency because of the perceived low yield of the test — which in any case depends on the population tested. Siblings of known AAT-deficient

subjects provide the highest yield (25% positive), but is the group with the fewest available subjects. Up to 3% of patients with chronic obstructive lung disease have AAT deficiency. As discussed above, most individuals with this disease worldwide are currently undiagnosed, and prolonged delays in making the correct diagnosis are common (54). Over the past few years there has been renewed interest in testing for AAT deficiency because of the importance of identifying current smokers with the condition and persuading them to quit and of initiating other therapies that might limit the development of lung disease.

Screening for AAT deficiency may be empirically divided into three types of activities: nondirected, or population screening of adults; directed screening of adults who have a higher-than-average risk of having AAT deficiency or of suffering from AAT-deficiency-related lung disease ("case-finding"); and neonatal screening programmes. Population screening of adults has been largely confined to blood donor populations (44) although useful for estimating the prevalence of undiagnosed AAT deficiency in the community, the yield is sufficiently low that it is not cost-effective to screen large populations of adults.

Since March 1991, the AAT Deficiency Detection Center in Salt Lake City, UT, USA, has offered testing to individuals with chronic bronchitis, emphysema and asthma, and also to those with a family history of AAT deficiency. In the 5 years ending 29 February 1996, 16 748 samples had been received for testing: 515 individuals were identified who had immunoreactive AAT levels <11 μ mol/l. Of these, one was phenotype PI^{SZ} and the remainder were phenotype PI^Z. Thus, 3.1% of the total samples submitted were from individuals with AAT deficiency, and it is estimated that the centre has diagnosed approximately 15% of the known individuals with AAT deficiency in the USA during its 5 years of operation.

Neonatal screening programmes, most notably those undertaken in the 1970s in Sweden and in Oregon, USA (200 000 and 107 038 neonates, resp.), enjoyed success in assessing the prevalence of AAT deficiency, and eventually will contribute to our knowledge of the natural history of the disease in adults as well as in early life (23, 32). Recently, there has been a small pilot screening effort in New York State (76), as well as some renewed discussion among workers involved in neonatal screening (77). Despite the potential for rearing identified neonates by focusing on a healthy lifestyle, and thus markedly lessening the lung disease morbidity in future generations (32) the advisability of neonatal screening for AAT deficiency has not been widely accepted.

Conclusions and recommendations

- Among Caucasian populations, AAT deficiency is as common a genetic disorder as cystic fibrosis. Available evidence indicates that in all countries with a high frequency of Caucasians, the number of diagnosed cases of AAT deficiency is only a small proportion of that predicted from estimates of gene frequency. The proportion of ascertained cases of AAT deficiency ranges from less than 10% in the USA and the United Kingdom to as high as 50% in smaller countries such as Denmark. Although there are insufficient amounts of human AAT available to provide augmentation therapy for all who might need it should all cases be ascertained, many alternative preventive measures could be put in place. These include counselling carriers not to smoke or to stop smoking; provision of adequate immunization against influenza and pneumococcal infection; occupational counselling to minimize breathing polluted air, appropriate treatment of respiratory infection and atopic disease; and genetic counselling. It is therefore recommended that all patients with COPD and adults and adolescents with asthma be screened once for AAT deficiency using a quantitative test. Those with abnormal results on screening should undergo PI typing.
- The 1995 ATS Standards of Care for COPD represent an important advance but deal with AAT deficiency in a limited manner. For example, liver disease in childhood, genetic counselling, and the importance of smoking avoidance programmes and infection control programmes are not stressed. Standards that are specific for the care of persons with severe AAT deficiency should be drafted and will require involvement by gastroenterologists, paediatricians and geneticists — and perhaps their national societies.
- Case finding among adults is too late to prevent COPD in many AAT-deficient persons, since the greatest risk factor for early-onset COPD is tobacco smoking. Because of the powerful addictive properties of smoking, even with maximal support, a small proportion of smokers stop (22% sustained quitters at 5 years in the Lung Health Study). Two studies in which AAT deficiency was ascertained by neonatal screening found much lower frequencies of smoking at adolescence than expected. Furthermore, there are many other preventive measures that can be taken. The following recommendations can therefore be made: neonatal AAT screening programmes should be undertaken in all developed countries with Caucasian populations; limited programmes of neonatal screening should be undertaken in devel-

oping countries to determine the frequency of genes leading to deficiency and the burden of resulting disease in those populations; implementation of a neonatal screening programme requires involvement by gastroenterologists, geneticists, paediatricians (especially those involved in neonatal screening) clinical pathologists, ethicists, health care lawyers and the allied health professions, in addition to pulmonary specialists. Before such a screening programme is undertaken, laws or regulations must be in place to protect persons found to be severely AAT deficient from possible negative impacts on insurance coverage. Permission of families for screening must be obtained and strong support measures must be in place to assure appropriate counselling and support to persons found to have AAT deficiency and to their families.

- An international α_1 -antitrypsin registry, with standardized requirements for case acquisition, would be difficult to establish because of differences in country-to-country practices and governmental funding of some existing registries; however, it should be possible to develop an international AAT coordinating registry (IAATCR). Such a registry would have as its function the development of standardized forms for data entry and the development of a centralized database for carrying out appropriate research. Research coordination and dissemination of information to member-country data bases also seems feasible and appropriate. The IAATCR could be funded by a mixture of governmental, foundation, and industry funds. It would require a director, who could be part-time, and who would report to a rotating board of directors made up of members from the national AAT registries. Also needed would be one or two full-time staff members for data management and computing equipment for data storage and analysis.
- There is an urgent need for randomized clinical trials of the efficacy of AAT augmentation therapy in persons with the deficiency. Information from the NHLBI AAT Deficiency Registry may indicate need for fewer subjects in such studies than was heretofore considered necessary. Among the needs for such clinical trials are a placebo-controlled, outcome-driven trial of AAT augmentation therapy; determination of the need for adjusting AAT dosing during exacerbations of COPD; determination of the minimum effective replacement dose of AAT; and the most appropriate timing of the regimens. There are many questions as to the best end points to be measured and of the study design. All appropriate groups should be represented, including investigators, representatives of national health care agencies, industry, patient groups and the managed health

care industry. These studies could be carried out nationally or internationally, depending on logistics. An international working party on randomized clinical trials should be appointed to address these issues and to make specific recommendations

• Specific research needs for AAT deficiency are shown below.

- *Structural basis of deficiency*: determine the precise molecular mechanisms involved in the misfolding and aggregation of Z α_1 -antitrypsin with a view to developing therapeutic strategies to inhibit aggregate formation and hence prevent liver disease and increase plasma levels of α_1 -antitrypsin.
- *Risk factors and prognosis of lung disease*: identify risk factors for emphysema other than cigarette smoking (infection, atopy, familial factors); determine the role of environmental factors as risk factors for emphysema; and establish the natural history of lung disease in AAT deficiency.
- *Description of the pathology of the lungs in AAT deficiency*: parenchyma; bronchi; bronchioles; and blood vessels.
- *Determination of the frequency, type, clinical and physiological manifestations of bronchiectasis in AAT deficiency*.
- *Specific therapy of lung disease due to AAT deficiency*: implement a randomized placebo-controlled clinical outcome trial of intravenous augmentation therapy; explore the role of markers of elastin degradation or other indicators in evaluating the effects of augmentation therapy; assuming that augmentation therapy is proven to be effective, determine the preferred regimen by head-to-head comparative trials; determine the specific role of augmentation therapy in patients after lung transplantation; further evaluate alternative therapies, including aerosolized recombinant AAT and synthetic elastase inhibitors; foster continuing work on the safety and efficacy of gene transfer as a possible therapeutic option for AAT deficiency; and determine the relative roles of lung volume reduction surgery and lung transplantation for emphysema due to AAT deficiency.
- *Liver disease in AAT deficiency*: foster research into the basic mechanisms of liver disease in AAT deficiency; determine the role of antioxidant therapy in preventing liver disease; determine whether breast-feeding is protective against neonatal liver disease; determine the frequency and risk factors for development of cirrhosis and

hepatocellular carcinoma in adults; determine the contribution of inflammation and hyperthermia to the accelerated accumulation of AAT in the hepatocyte and hence the exacerbation of liver damage; determine the efficacy and advisability of vaccination against viral hepatitis B, and when a vaccine becomes available, against viral hepatitis C.

— *Determination of gene frequency of AAT-deficient alleles in developing countries and the associated disease burden*

— *Analysis of the costs and benefits of screening, as a prelude to implementing neonatal screening for AAT deficiency*.

Acknowledgements

The participants at the meeting thank the following individuals. Mrs S. Brandley, and Mr J. Brandley (representatives of the Alpha-1 National Association); Dr K. Allenby, Mrs D.P. Grange, Dr R. Gundel, Dr R.A. Lutes, Dr P. Fernandez, Dr R. Rousell (representatives of Bayer Corporation), Dr S. Kee; Dr J.J. Petillo and Dr R. Schwartz (representatives of Centeon)

Résumé

Déficit en α_1 -antitrypsine: Mémoire d'une réunion de l'OMS

Le déficit en α_1 -antitrypsine (AAT), connu également sous le nom de déficit en inhibiteur de l' α_1 -protéase, est une maladie imputable à un déficit génétiquement déterminé en AAT. Le déficit résulte de la transmission de deux allèles codant pour le déficit en inhibiteur de protéase (PI) au niveau du locus du gène AAT (désigné par PI) localisé sur le segment chromosomique 14q32.1. L'allèle codant pour le déficit le plus connu est PI^*Z , et la majorité des sujets atteints de déficit sévère en AAT ont un locus PI de type ZZ. La maladie survient essentiellement chez des blancs d'origine européenne, et sa fréquence en Europe et en Amérique du Nord est comparable à celle de la mucoviscidose (1 pour 2000 à 1 pour 7000). Une personne atteinte peut ne pas avoir de manifestations cliniques. La pneumopathie obstructive chronique (POC) avec un emphysème panacinaire de fréquence élevée, est le trait clinique le plus fréquemment associé au déficit en AAT et la cause la plus fréquente d'incapacité et de décès. Le tabagisme est le facteur de risque le plus important d'apparition d'une POC, laquelle survient avant la trentaine, c'est-à-dire beaucoup plus tôt que la POC classique survenant en l'absence de déficit. La maladie de foie, la deuxième

Memorandum

manifestation par ordre de fréquence du déficit en AAT, se présente typiquement comme une cholestase du nourrisson qui en général n'est pas grave et régresse avant l'adolescence. Il est rare qu'apparaisse une hépatopathie chronique, bien que le déficit en AAT soit la cause la plus fréquente d'hépatopathie chronique de l'enfant. La cirrhose et le cancer du foie touchent au moins 25% des adultes de plus de 50 ans porteurs d'un déficit en AAT. Le déficit en AAT paraît largement sous diagnostiqué, et compte tenu de la fréquence attendue des gènes, seule une petite partie des cas attendus de déficit en AAT ont été diagnostiqués, même dans les populations les mieux étudiées. L'AAT humaine pour le traitement de supplémentation n'est disponible qu'en petite quantité.

Une réunion de l'OMS s'est tenue à Genève, du 18 au 20 mars 1996, pour faire le point des connaissances sur cette affection génétique très fréquente, pour mettre au point une stratégie afin de sensibiliser les prestataires de soins et la population générale, et pour rechercher des stratégies nouvelles de dépistage et de prévention de la maladie. Les recommandations formulées par les participants sont résumées cidessous.

- Parmi les sujets de race blanche, le déficit en AAT est une anomalie génétique aussi fréquente que la mucoviscidose, mais le nombre de cas diagnostiqués ne représente qu'une faible partie des cas attendus d'après la fréquence du gène. Les mesures préventives suivantes pourraient être mises en place: conseiller aux porteurs de ne pas fumer ou d'arrêter le tabagisme; prestations vaccinales adaptées contre la grippe; conseil, pour diminuer la quantité d'air pollué respiré en milieu professionnel; traitement approprié des infections respiratoires et de l'atopie; conseil génétique.
- Elaboration d'un projet de traitement codifié spécifique des personnes atteintes de déficit sévère en AAT
- Dépistage néonatal du déficit en AAT dans tous les pays développés ayant des populations blanches, programmes limités de dépistage néonatal dans les pays en développement pour déterminer la fréquence des gènes entraînant le déficit et la charge pathologique associée pour ces populations; la mise en œuvre d'un programme néonatal de dépistage implique le travail de spécialistes appartenant à de très nombreuses disciplines. Avant que ce type de programme soit appliqué, il est nécessaire d'instituer des lois et une réglementation pour protéger les personnes atteintes de déficit sévère en AAT contre les effets négatifs possibles de ce dépistage sur la couverture par les assurances. De plus, l'autorisation des familles devra être obtenue pour pratiquer le dépistage, et des mesures importantes de soutien doivent être mises en place afin d'assurer un conseil approprié et l'aide aux personnes atteintes et à leur famille.
- Mise en place d'un registre international de coordination pour l'AAT.
- Création d'un groupe international de travail pour les essais cliniques randomisés sur le déficit en AAT.
- Des travaux de recherche s'imposent dans les domaines suivants.
 - les bases structurales du déficit en AAT;
 - les facteurs de risque et le pronostic de la pneumopathie chez les personnes atteintes de déficit en AAT;
 - la pathologie pulmonaire observée avec le déficit en AAT;
 - la fréquence, le type et les manifestations cliniques et physiologiques de la bronchectasie observées avec le déficit en AAT;
 - le traitement approprié de la pneumopathie due au déficit en AAT;
 - l'hépatopathie du déficit en AAT;
 - la fréquence des allèles du déficit en AAT dans les pays en développement et la charge pathologique associée,
 - les coûts et les avantages du dépistage, en préparation du dépistage néonatal du déficit en AAT.

References

1. **Laurell C-B, Eriksson S.** The electrophoretic α_1 -globulin pattern of serum in α_1 -antitrypsin deficiency. *Scandinavian journal of clinical and laboratory investigation*, 1963, **15**: 132-140
2. **Eriksson S.** Studies in α_1 -antitrypsin deficiency. *Acta medica scandinavica*, 1965, **432**: 1-85.
3. **Travis J, Salvesen GS.** Human plasma proteinase inhibitors. *Annual review of biochemistry*, 1983, **52**: 655-709.
4. **Carrell RW, Boswell DR.** Serpins: the superfamily of plasma serine proteinase inhibitors. In: Barrett A, Salvesen G, eds. *Proteinase inhibitors*. Amsterdam. Elsevier Biomedical Press, 1986: 403-419
5. **Potempa J, Korzus E, Travis J.** The serpin family of proteinase inhibitors. structure, function and regulation. *Journal of biological chemistry*, 1994, **269**: 15957-15960
6. **Huber R, Carrell RW.** Implications of the three-dimensional structure of α_1 -antitrypsin for structure

- and function of serpins. *Biochemistry*, 1989, **28**: 8951–8966
7. **Engh RA et al.** Divining the serpin inhibition mechanism: a suicide substrate "spring"? *Trends in biotechnology*, 1995 **B**: 503–510
 8. **Carrell RW, Stein PE.** The biostructural pathology of the serpins. *Biological chemistry. Hoppe-Seyler*, 1996, **377**: 1–17
 9. **Stein PE, Carrell RW.** What do dysfunctional serpins tell us about molecular mobility and disease? *Nature structural biology*, 1995, **2**: 96–114.
 10. **Carrell RW et al.** Structure and variation of human α_1 -antitrypsin. *Nature*, 1982, **298**: 329–334
 11. **Jeppson J-O.** Amino acid substitution Glu¹⁹¹/Elys in α_1 -antitrypsin PiZ. *FEBS letters* 1976, **65**: 195–197
 12. **Yoshida A et al.** Molecular abnormality of human α_1 -antitrypsin variant (Pi-ZZ) associated with plasma activity deficiency. *Proceedings of the National Academy of Sciences of the USA*, 1976, **73**: 1324–1328.
 13. **Graham A et al.** Molecular characterisation of three alpha-1-antitrypsin deficiency variants: proteinase inhibitor (Pi) null_{Ca dli} (Asp²³⁵/EVal). Pi M_{Maltion} (Phe⁶¹/Edeletion) and Pi(Arg³²/ECys) *Human genetics*, 1989, **84**: 55–58
 14. **Frazier GC et al.** In-frame single codon deletion in the Mmaltion deficiency allele of α_1 -antitrypsin *American journal of human genetics*, 1989 **44**: 894–902
 15. **Seyama K et al.** S_{met-a} (Serine53 (TCC) to phenylalanine 53 (TCC)) *Journal of biological chemistry*, 1991, **266**: 12627–12632.
 16. **Yu M-H, Lee K-N, Kim J.** The Z-type variant of human α_1 -antitrypsin causes a protein folding defect *Nature structural biology*, 1995, **2**: 363–367.
 17. **Le A, Graham KS, Sifers RN.** Intracellular degradation of the transport impaired human PiZ α_1 -antitrypsin variant. *Journal of biological chemistry*, 1990, **265**: 14001–14007
 18. **Lomas DA et al.** The mechanism of Z α_1 -antitrypsin accumulation in the liver. *Nature* 1992, **357**: 605–607.
 19. **Lomas DA et al.** α_1 -Antitrypsin Siiyama (Ser⁵³/E Phe): further evidence for intracellular loop-sheet polymerisation. *Journal of biological chemistry*, 1993, **268**: 15333–15335.
 20. **Cox DW.** α_1 -Antitrypsin deficiency In: Scriver CR et al., eds *The metabolic and molecular bases of inherited disease*, 7th ed. New York, McGraw-Hill, 1995 4125–4158.
 21. **Lieberman J.** Alpha₁-antitrypsin deficiency and related disorders. In Emery AEH, Rimolin DL, eds. *Principles and practice of medical genetics*, vol 2. New York, Churchill Livingstone, 1983: 911–935
 22. **Kamboh MI.** Biochemical and genetic aspects of human serum α_1 -proteinase inhibitor protein *Disease markers*, 1985, **3**: 135.
 23. **Sveger T.** Liver disease in alpha₁-antitrypsin deficiency detected by screening of 200000 infants *New England journal of medicine*, 1976, **294**: 1316–1321
 24. **Cox DW, Billingsley GD.** Rare deficiency types of α_1 -antitrypsin: electrophoretic variation and DNA haplotypes. *American journal of human genetics* 1989, **44**: 844–854
 25. **Cox DW, Billingsley GD, Smyth S.** Rare types of α_1 -antitrypsin associated with deficiency In Allen RC, Arnaud P, eds. *Proceedings of the Third International Conference on Electrophoresis, 1981*. New York New York de Gruyter, 1981: 505–510
 26. **Cox DW, Billingsley GD, Mansfield T.** DNA restriction site polymorphisms associated with the alpha₁-antitrypsin gene. *American journal of human genetics*, 1987 **41**: 891–906.
 27. **Hodgson I, Kalsheker N.** DNA polymorphisms of the human α_1 antitrypsin gene in normal subjects and in patients with pulmonary emphysema *Journal of medical genetics*, 1987, **24**: 47–51.
 28. **Cox DW, Woo SLC, Mansfield T.** DNA restriction fragments associated with alpha₁-antitrypsin indicate a single origin for deficiency allele PiZ *Nature* 1985, **316**: 79–81.
 29. **Brantly M, Nukiwa T, Crystal RG.** Molecular basis of alpha-1-antitrypsin deficiency. *American journal of medicine*, 1988, **84** (suppl 6A) 13–31.
 30. **Brantly ML et al.** Clinical features and history of the destructive lung disease associated with alpha-1-antitrypsin deficiency of adults with pulmonary symptoms *American review of respiratory disease*, 1988, **138**: 327–336.
 31. **Gishen P et al.** Alpha-1-antitrypsin deficiency: the radiological features of pulmonary emphysema in subjects of Pi-type Z and Pi-type SZ: a survey by the British Thoracic Association *Clinical radiology*, 1982, **33**: 371–377.
 32. **Wall M et al.** Long-term follow-up of a cohort of children with alpha-1-antitrypsin deficiency *Journal of pediatrics*, 1990, **116**: 248–251.
 33. **Tobin MJ, Cook PJJ, Hutchison DCS.** Alpha₁-antitrypsin deficiency: the clinical and physiological features of pulmonary emphysema in subjects homozygous for Pi Type Z *British journal of disease of the chest*, 1983, **77**: 14–27
 34. **Janus ED, Phillips NT, Carrell RW.** Smoking lung function, and alpha-1-antitrypsin deficiency *Lancet*, 1985, **1**: 152–154
 35. **The Alpha-1-Antitrypsin Deficiency Registry Study Group.** A registry of patients with severe deficiency of alpha-1-antitrypsin: design and methods *Chest*, 1994, **106**: 1223–1233
 36. **Larsson C.** Natural history and life expectancy in severe alpha₁-antitrypsin deficiency, PiZ. *Acta medica scandinavica*, 1978, **204**: 345–351.
 37. **Eriksson S.** Studies in alpha-1-antitrypsin deficiency. *Acta medica scandinavica*, 1965, **177**: 1–85
 38. **Waller RE.** Field investigations of air In Holland WW et al., eds. *Oxford textbook of public health* vol. 2, 2nd edit Oxford. Oxford University Press 1991 435–450
 39. **Abbey DE et al.** Estimated long-term ambient concentrations of PM10 and development of respiratory symptoms in a nonsmoking population *Archives of environmental health*, 1995 **50**: 139–152
 40. **Schwartz J.** Air pollution and hospital admissions for the elderly in Detroit, Michigan *American journal of respiratory and critical care medicine*, 1995, **150**: 648–655

Memorandum

41. **Bakke PS et al.** Prevalence of obstructive lung disease in a general population. relation to occupational title and exposure to some airborne agents. *Thorax*, 1991, **46**: 863–870.
42. **Shaheen SO et al.** The relationship between pneumonia in early childhood and impaired lung function in late adult life. *American journal of respiratory and critical care medicine*, 1994, **149**: 616–619.
43. **Shaheen SO et al.** Do lower respiratory tract infections in early childhood cause chronic obstructive pulmonary disease? *American journal of respiratory and critical care medicine*, 1995, **151**: 1649–1652.
44. **Silverman EK et al.** Alpha-1-antitrypsin deficiency. High prevalence in the St. Louis area determined by direct population screening. *American review of respiratory disease*, 1989, **140**: 961–966.
45. **Monso E et al.** Bacterial infection in chronic obstructive pulmonary disease. A study of stable and exacerbated outpatients using the protected specimen brush. *American journal of respiratory and critical care medicine*, 1995, **152**: 1316–1320.
46. **Silverman EK et al.** Variability of pulmonary function in alpha-1-antitrypsin deficiency: residual family resemblance beyond the effect of the Pi locus. *Human heredity*, 1990, **40**: 340–355.
47. **Wright JL et al.** Airway inflammation and peribronchiolar attachments in the lungs of nonsmokers, current and ex-smokers. *Lung*, 1988, **166**: 277–286.
48. **Snider GL.** Emphysema: the first two centuries — and beyond; a historical overview. with suggestions for future research: part 2. *American review of respiratory disease*, 1992, **146**: 1615–1622.
49. **Stockley RA et al.** Elastase inhibitors of sputum sol phase variability, relationship to neutrophil elastase inhibition, and effect of corticosteroid treatment. *Thorax*, 1986, **41**: 442–447.
50. **Shin MS, Ho K-J.** Bronchiectasis in patients with alpha-1-antitrypsin deficiency: a rare occurrence? *Chest*, 1993, **104**: 1384–1386.
51. **Seersholm N, Kok-Jensen A.** Survival in relation to lung function and smoking cessation in patients with severe hereditary alpha-1-antitrypsin deficiency. *American journal of respiratory and critical care medicine*, 1995, **151**: 369–373.
52. **Seersholm N, Kok-Jensen A, Dirksen A.** Survival of patients with severe alpha-1-antitrypsin deficiency with special reference to non-index cases. *Thorax*, 1994, **49**: 695–698.
53. **Lieberman J, Winter B, Sastre A.** Alpha-1-antitrypsin PI-types in 965 COPD patients. *Chest*, 1986, **89**: 370–373.
54. **Stoller JK et al.** Physical and social impact of alpha-1-antitrypsin deficiency: results of a mail survey of the readership of a national newsletter. *Cleveland Clinic journal of medicine*, 1995, **61**: 461–467.
55. **Sharp HL et al.** Cirrhosis associated with alpha-1-antitrypsin deficiency. a previously unrecognized inherited disorder. *Journal of laboratory and clinical medicine*, 1969, **73**: 934–939.
56. **Berg NO, Eriksson S.** Liver disease in adults with alpha-1-antitrypsin deficiency. *New England journal of medicine*, 1972, **287**: 1264–1267.
57. **Cox DW, Smyth S.** Risk for liver disease in adults with alpha-1-antitrypsin deficiency. *American journal of medicine*, 1983, **74**: 221–227.
58. **Propst T et al.** Prevalence of hepatocellular carcinoma in alpha-1-antitrypsin deficiency. *Journal of hepatology*, 1994, **21**: 1006–1011.
59. **Eriksson S, Carlson J, Velez R.** Risks of cirrhosis and primary liver cancer in alpha-1-antitrypsin deficiency. *New England journal of medicine*, 1986, **314**: 736–739.
60. **Propst T et al.** High prevalence of viral infection in adults with homozygous and heterozygous alpha-1-antitrypsin deficiency and chronic liver disease. *Annals of internal medicine*, 1992, **117**: 641–645.
61. **Edmonds BK, Hodge JA, Rietschel RL.** Alpha-1-antitrypsin deficiency-associated panniculitis. Case report and review of the literature. *Pediatric dermatology*, 1991, **8**: 296–299.
62. **McNeil TF, Sveger T, Theelin T.** Psychosocial effects of screening for somatic risk: the Swedish alpha-1-antitrypsin experience. *Thorax*, 1988, **43**: 505–507.
63. **Hubbard RC et al.** Biochemical efficacy and safety of monthly augmentation therapy for alpha-1-antitrypsin deficiency. *Journal of the American Medical Association*, 1988, **260**: 1259–1264.
64. **Cammarata SK et al.** Failure to achieve adequate serum levels with monthly replacement therapy in alpha-1-antitrypsin deficiency. *Chest*, 1994, **106**: 651–652.
65. **Casolaro MA et al.** Augmentation of lung antineutrophil elastase capacity with recombinant human alpha-1-antitrypsin. *Journal of applied physiology*, 1987, **63**: 2015.
66. **Seersholm N et al.** Annual decline in FEV₁ in patients with severe alpha-1-PI deficiency: comparison of 161 untreated Danish and 235 German patients receiving augmentation therapy. *American journal of respiratory and critical care medicine*, 1995, **151**: A835.
67. **Boris-Lawrie KA, Temin HM.** Recent advances in retrovirus technology. *Current opinion in genetic development*, 1993, **301**: 353–362.
68. **Garver RI et al.** Clonal gene therapy transplanted mouse fibroblast clones express human alpha-1-antitrypsin gene *in vivo*. *Science*, 1987, **237**: 762–764.
69. **Kolodka TM, Finegold M, Woo SLC.** Hepatic gene therapy: efficient retroviral-mediated gene transfer into rat hepatocytes *in vivo*. *Somatic cell and molecular genetics*, 1993, **19**: 491–497.
70. **Curriel D, Stier L, Crystal RG.** Gene therapy for alpha-1-antitrypsin deficiency using lymphocytes as vehicles for alpha-1-antitrypsin delivery. *Clinical research*, 1989, **37**: 578A.
71. **Strauss SE.** In: Ginsberg H, ed. *The adenoviruses*. New York, Plenum Press, 1984: 451–496.
72. **Jaffe HA et al.** Adenovirus-mediated *in vivo* gene transfer and expression in normal rat liver. *Nature genetics*, 1992, **1**: 368–371.
73. **Canonico AE et al.** Aerosol and intravenous transfection of human alpha-1-antitrypsin gene to lungs of rabbits. *American journal of respiratory cell and molecular biology*, 1994, **10**: 24–29.
74. **Michael SI, Curriel DT.** Strategies to achieve targeted gene delivery via the receptor-mediated endocytosis pathway. *Gene therapy*, 1994, **1**: 223–232.

75. **Jeppsson JO, Franzen B.** Typing of genetic variants of α_1 -antitrypsin by electrofocusing. *Clinical chemistry*, 1982, **28**: 219–225
76. **Spence WC, Pass K, Murphy PD.** A rapid fluorometric assay for newborn screening of α_1 -antitrypsin followed by phenotyping of deficient specimens by isoelectric focusing. *Screening*, 1994, **3**: 23–31
77. **Niggemann B, Paul K.** α_1 -Antitrypsin deficiency: a need for screening? *Screening*, 1992, **1**: 195–201.
78. **Sveger T, Eriksson S.** The liver adolescents with α_1 -antitrypsin deficiency. *Hepatology*, 1995, **22**: 514–517.
79. **Hutchison DCS et al.** Longitudinal studies in alpha-1-antitrypsin deficiency: a survey by the British Thoracic Society. In Taylor JC, Mittman C. eds. *Pulmonary emphysema and proteolysis*. New York, Academic Press, 1987: 7–15.
80. **Wu MC, Eriksson S.** Lung function, smoking, and survival in severe alpha-1-antitrypsin deficiency, PI*ZZ. *Journal of clinical epidemiology*, 1988, **41**: 1157–1165.
81. **Buist AS et al.** The natural history of air-flow obstruction in PiZ emphysema. *American review of respiratory disease*, 1983, **127** (suppl): S43–S50



Control of Hereditary Diseases

Report of a WHO Scientific Group

This report provides an expert assessment of striking recent developments in molecular genetics and their implications for medical practice, at present and in the immediate future. Adopting a public health approach, the report aims to help medical decision-makers and practitioners understand both the technical basis of progress and its potential to revolutionize the management of numerous diseases. Advances in the prevention and treatment of classical genetic disorders are considered together with newer opportunities opened by knowledge that many common disorders, including coronary heart disease and certain cancers, have a genetic component.

Throughout the report, a special effort is made to help planners, in developing and developed countries alike, reap the full public health benefits of technologies that are becoming increasingly powerful, simple, and inexpensive to use. Information ranges from a discussion of the state-of-the-art in gene therapy, through a tabular summary of treatment results for specific congenital anomalies, to advice on ways to integrate simple genetic approaches into everyday medical practice. Relevant ethical, social, and legal issues are also critically assessed in an effort to provide comprehensive guidance.

The report has eight sections. Background information is provided in the first, which explains the structure and functions of DNA, summarizes knowledge about the genetic basis of both single-gene and multifactorial disorders, and traces the spectacular development of DNA technology and diagnostic tests over the past decade. The Human Genome Project – and its potential to transform medical practice on many lev-

els – are also explained in detail. A section on epidemiology discusses factors influencing the frequency of genetic and congenital disorders and describes opportunities for their management and prevention. The impact that these advances will have on the demand for genetic services is also assessed.

The large scale of implications for medical practice is underscored in the third section, which reviews and interprets growing knowledge about the genetic component of many common disorders, including coronary heart disease, certain cancers, asthma, diabetes, mental disorders, and Alzheimer disease. A comprehensive review of current and future opportunities for prevention, including both genetic family studies and population screening, is followed by sections covering the basic principles of genetic counselling and opportunities, within the context of obstetric care, for prenatal diagnosis using ultrasound scanning and DNA technology.

The remaining sections offer advice on the organization of genetic services in industrialized and developing countries alike, and discuss the ethical, social and legal aspects of genetic technology in medicine, concluding that the broadest ethical issue in the area of genetic services is their limited availability.

Control of Hereditary Diseases

Report of a WHO Scientific Group

WHO Technical Report Series, No 865

1996, v + 84 pages (available in English, French and Spanish in preparation)

ISBN 92 4 120865 1; order no. 1100865

Sw.fr. 16.–/US \$14.40

In developing countries: Sw.fr. 11.20